

# TECH TECH CONTROLLERS

USER MANUAL

EU-11

EN



[www.tech-controllers.com](http://www.tech-controllers.com)

## TABLE OF CONTENTS

I.	Safety.....	3
II.	Description of the device .....	4
III.	How to install water flow sensor.....	4
IV.	Main screen description.....	7
V.	Controller menu .....	7
1.	Block diagram – main menu .....	7
2.	Language .....	8
3.	Pre-set circ. temp. ....	8
4.	Operation time .....	8
5.	Pre-set thresh. temp. ....	8
6.	Manual operation.....	9
7.	Anti-stop ON/OFF .....	9
8.	Factory settings .....	9
9.	About.....	9
VI.	Technical data .....	9
VII.	Alarms and problems .....	10

## I. SAFETY

Before using the device for the first time the user should read the following regulations carefully. Not obeying the rules included in this manual may lead to personal injuries or controller damage. The user's manual should be stored in a safe place for further reference. In order to avoid accidents and errors it should be ensured that every person using the device has familiarized themselves with the principle of operation as well as security functions of the controller. If the device is to be sold or put in a different place, make sure that the user's manual is there with the device so that any potential user has access to essential information about the device.

The manufacturer does not accept responsibility for any injuries or damage resulting from negligence; therefore, users are obliged to take the necessary safety measures listed in this manual to protect their lives and property.



### WARNING

- **High voltage!** Make sure the regulator is disconnected from the mains before performing any activities involving the power supply (plugging cables, installing the device etc.).
- The device should be installed by a qualified electrician.
- The regulator should not be operated by children.



### WARNING

- The device may be damaged if struck by a lightning. Make sure the plug is disconnected from the power supply during storm.
- Any use other than specified by the manufacturer is forbidden.
- Before and during the heating season, the controller should be checked for condition of its cables. The user should also check if the controller is properly mounted and clean it if dusty or dirty.

---

Changes in the merchandise described in the manual may have been introduced subsequent to its completion on March 15.03.2021. The manufacturer retains the right to introduce changes to the structure. The illustrations may include additional equipment. Print technology may result in differences in colours shown.

---

Care for the natural environment is our priority. Being aware of the fact that we manufacture electronic devices obligates us to dispose of used elements and electronic equipment in a manner which is safe for nature. As a result, the company has received a registry number assigned by the Main Inspector of Environmental Protection. The symbol of a crossed out rubbish bin on a product means that the product must not be thrown out to ordinary waste bins. By segregating waste intended for recycling, we help protect the natural environment. It is the user's responsibility to transfer waste electrical and electronic equipment to the selected collection point for recycling of waste generated from electronic and electrical equipment.



## II. DESCRIPTION OF THE DEVICE

DHW circulation regulator is intended for controlling DHW circulation to suit individual user's needs. In an economical and convenient way, it reduces the time needed for hot water to reach the fixtures. It controls the circulating pump which, when the user draws water, accelerates the flow of hot water to the fixture, exchanging the water there for hot water at the desired temperature in the circulation branch and at the tap. The system monitors the temperature set by the user in the circulation branch and it activates the pump only when the pre-set temperature is lowered. Thus it does not generate any heat loss in the DHW system. It saves energy, water and equipment in the system (eg circulation pump).

The circulation system operation is activated again only when hot water is needed and at the same time the pre-set temperature in the circulation branch drops.

The device regulator offers all the functions necessary to adjust to various DHW circulation systems. It may control hot water circulation or enable the circulating pump in case of heat source overheating (e.g. in solar heating systems). The device offers pump anti-stop function (protecting against rotor lock) and adjustable working time of circulation pump (defined by the user).

### Additional functionalities:

- possibility of activating the pump e.g. for heat treatment of the system / anti-legionella function
- multilingual menu
- compatible with other devices e.g. DHW tank (DHW exchanger), continuous-flow water heater

The device is an intelligent, ecological solution for all hot water circulation circuits or other systems that perform similar functions.

## III. HOW TO INSTALL WATER FLOW SENSOR

The water flow sensor should be mounted on the cold water supply of the appliance (e.g. water tank) whose circulation of hot water will be operated by the controller. Upstream of the sensor, it is necessary to mount a shut-off valve, a filter preventing against contamination and possible damage of the device, as well as a check valve. The device may be positioned vertically, horizontally or diagonally. Prior to mounting it on the piping system, remove the electronic sensor by undoing 2xM4 screws from the sensor body. Once mounted on the piping system, the sensor should be screwed onto the body.

The body of the flow sensor is equipped with 2 conical external threads  $\frac{3}{4}$  that should be sealed in some way, ensuring tight connection.

Use tools which do not damage the mechanical brass body of the device. Mount the body in accordance with the water flow direction and the markings, and then connect the sensor wires to the control circuit following the connection diagram.

The sensor should be mounted in a way which protects the electronical parts from dampness and eliminates any mechanical stress in the system.

# Domestic Hot Water recirculation function - single-function boiler with external tank

## Cyrkulacja c.w.u. - kocioł jednofunkcyjny z zasobnikiem

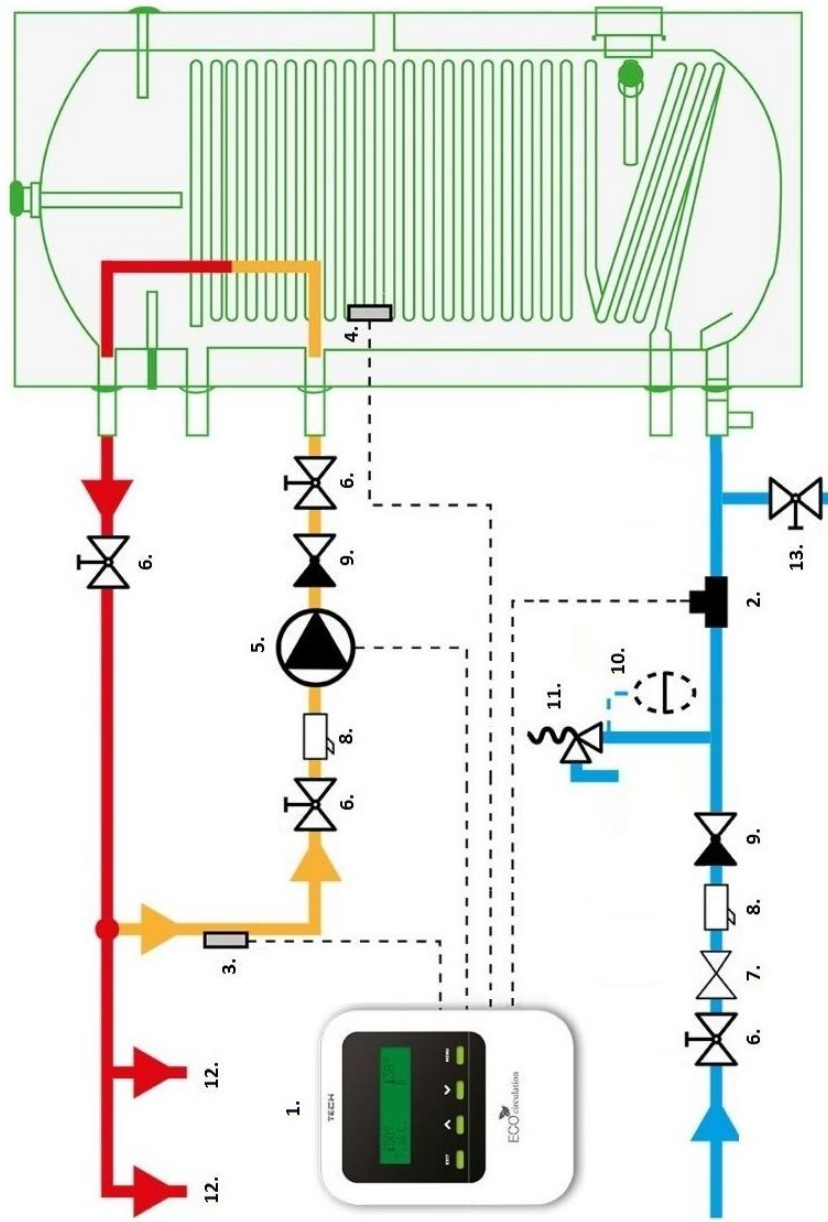

1. „Eco-circulation” controller / Sterownik „Eco circulation”
2. Flow sensor / Czujnik przepływu
3. Temperature sensor 1 / Czujnik temp. 1 (Circ. sensor)
4. Temperature sensor 2 / Czujnik temp. 2 Threshold sensor, Set. circ. sensor)
5. Pump / Pompa
6. Shut-off valve / Zawór odcinający
7. Pressure reducer / Reduktor ciśnienia
8. Water filter / Filtr wody
9. Non return valve / Zawór zwrotny
10. Expansion vessel / Naczynie przeponowe
11. Safety valve / Zawór bezpieczeństwa
12. Taps / Zawory czerpalne
13. Drain valve / Zawór spustowy

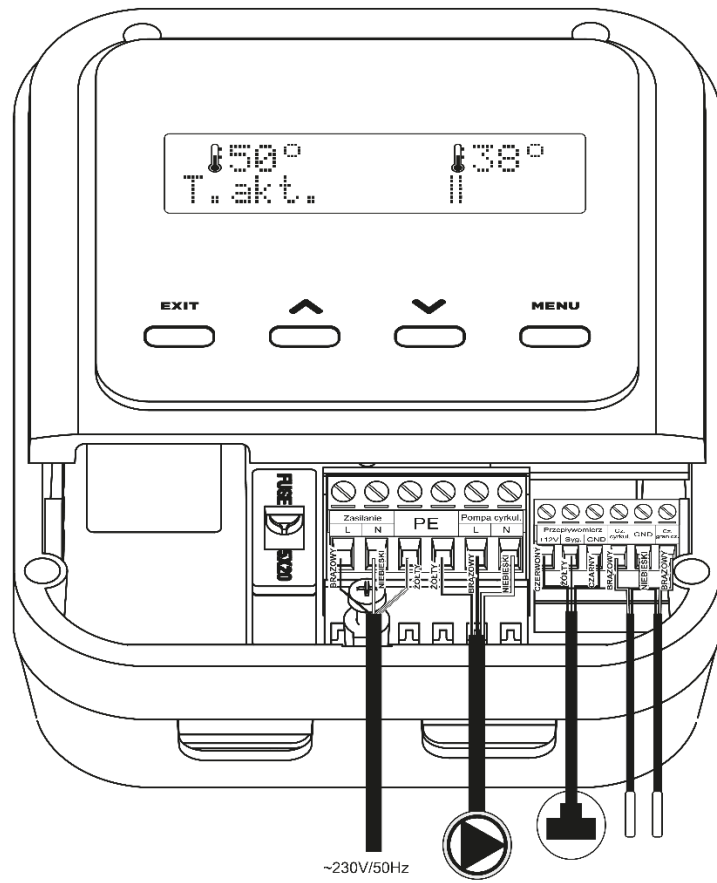

~230V/50Hz

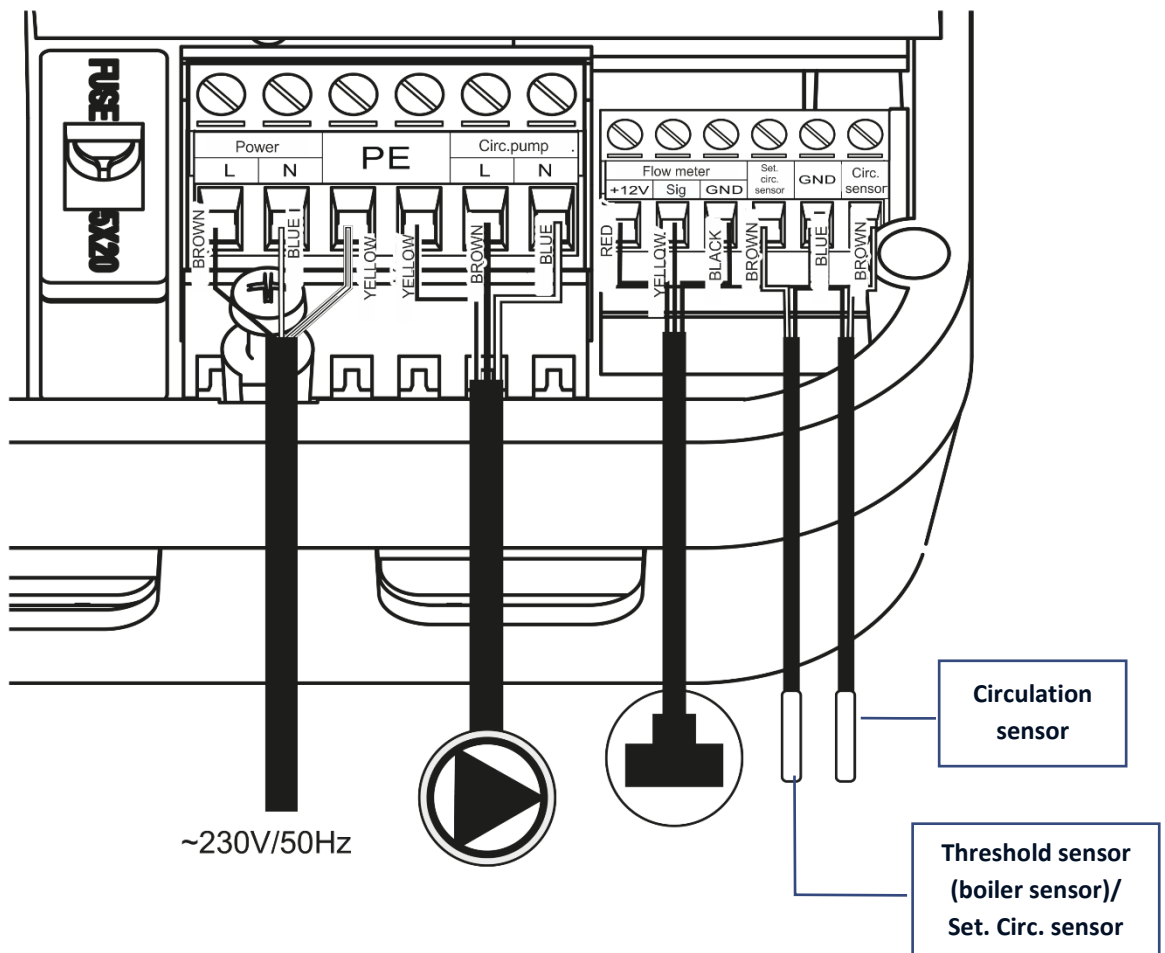

~230V/50Hz

Circulation sensor

Threshold sensor (boiler sensor)/ Set. Circ. sensor

## IV. MAIN SCREEN DESCRIPTION



1. Current temperature
2. EXIT button – exit the controller menu, cancel the settings.
3. 'up' button – view menu options, increase the value while editing parameters.
4. 'down' button – view menu options, decrease the value while editing parameters.
5. MENU button – enter the controller menu, confirm new settings.
6. Pump operation status („||” – the pump is inactive, „>” - the pump is active), or operation countdown clock.
7. Circulating temperature reading.

## V. CONTROLLER MENU

### 1. BLOCK DIAGRAM – MAIN MENU

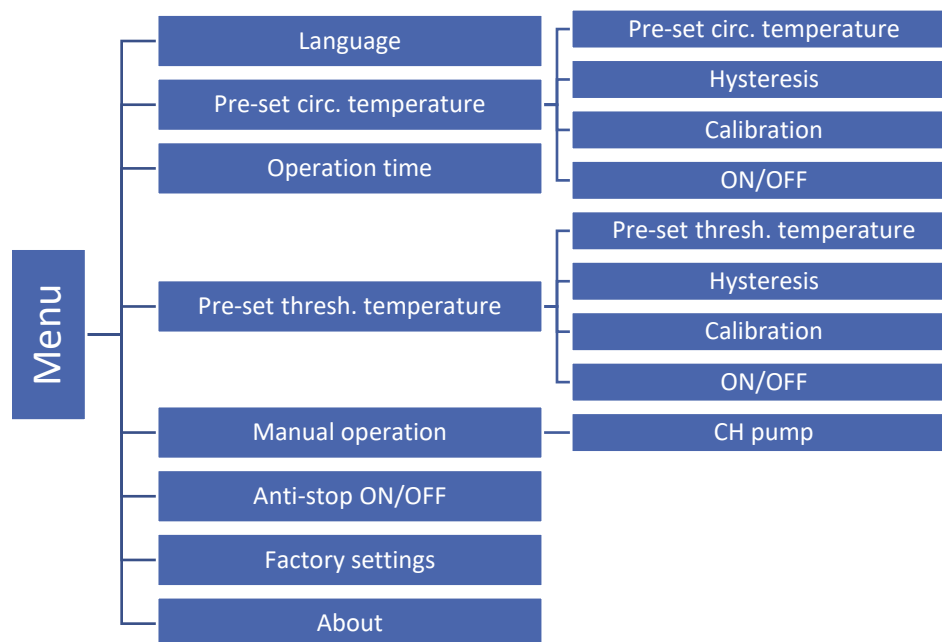

## 2. LANGUAGE

This function is used to select the language of the controller menu.

## 3. PRE-SET CIRC. TEMP.

This function enables the user to define the pre-set circulation temperature and hysteresis. When the flow sensor detects flowing water and the temperature is lower than the pre-set value, the pump will be enabled. It will be disabled when the pre-set <operation time> is over.

### Example:

Pre-set circulation temperature: 38°C

Hysteresis: 1°C

The pump will be enabled when the temperature drops below 37°C. When it increases above 38°C, the pump will not be enabled.

If the sensor is deactivated (ON/OFF function) and the temperature reaches its maximum value + 1°C, the pump will be enabled and it will remain active until the temperature drops by 10°C.



### NOTE

Once the sensor is deactivated (ON/OFF function), the alarm will not be activated.

## 4. OPERATION TIME

This function is used to define the operation time of the pump once it is activated by the flow sensor or anti-stop.

## 5. PRE-SET THRESH. TEMP.

This function is used to define the pre-set threshold temperature and hysteresis. Once this function is selected, the pump will be enabled when the threshold temperature is exceeded and it will remain active until the threshold temperature drops below the pre-set circulation temperature minus hysteresis.

### Example:

Pre-set threshold temperature: 85°C

Hysteresis: 10°C

The pump will be enabled when the temperature of 85°C is exceeded. When the temperature drops to 80°C (pre-set thresh.temp. – hysteresis), the pump will be disabled.



### NOTE

The pre-set circulation (threshold) temperature is displayed on the main screen, above the pump status icon.

If the circulation sensor is disabled (the ON/OFF function) and the temperature reaches the maximum value + 1°C, the pump will be enabled and it will operate until the temperature drops below the pre-set hysteresis.



**NOTE**

Once the sensor is deactivated (ON/OFF function), the alarm will not be activated.

**6. MANUAL OPERATION**

Once this option is selected, the user can activate particular devices manually (e.g. CH pump) in order to check if they operate properly.

**7. ANTI-STOP ON/OFF**

This function forces the activation of pumps to prevent limestone depositing during long periods of pump standstill. Once this function is selected, the pump will be enabled once a week for a pre-defined time (<Operation time>).

**8. FACTORY SETTINGS**

The controller is pre configured for operation. However, the settings should be customized to the user's needs. All the parameter changes introduced by the user are saved and they are not deleted even in the event of power failure. In order to restore factory settings, select <Fact. Settings> in the main menu. It enables the user to restore the settings saved by the controller manufacturer.

**9. ABOUT**

Once this function is selected, the main screen displays the name of the manufacturer and the controller software version.

**NOTE**

When contacting TECH service department, it is necessary to provide the controller software version.

## VI. TECHNICAL DATA

Specification	Value
Supply voltage	230V ± 10%/ 50Hz
Maximum power consumption of the controller	< 3,5W
Operation temperature	5°C ÷ 50°C
Thermal resistance of the sensors	-30°C ÷ 99°C

## VII. ALARMS AND PROBLEMS

In case of an alarm, the displays shows an appropriate message.

Alarm	Possible cause	Solution
Circulation sensor damaged	- Short-circuit or sensor interruption	<ul style="list-style-type: none"> <li>- Change the sensor location</li> <li>- Check if the wires in the controller terminal block are connected properly</li> <li>- Check if the wire has not been damaged</li> <li>- Interchange the sensors to check if they work properly</li> <li>- Check the sensor resistance</li> <li>- Replace the sensor</li> </ul>
Pre-set circulation (boiler sensor) sensor damaged		

The table below presents possible problems which may occur while using the regulator, as well as ways of solving them.

Problem	Solution
The controller display does not show any data	<ul style="list-style-type: none"> <li>- Check supply voltage (230V AC) at the socket</li> <li>- Check the fuse under the controller housing</li> </ul>
The circulating pump does not work	<ul style="list-style-type: none"> <li>- Check if the wires in the terminal block of the controller, flow sensor or pump are connected properly</li> <li>- Check if the pump operates properly</li> </ul>
No hot water circulation in the system	<ul style="list-style-type: none"> <li>- Vent the DHW system at its furthest point</li> <li>- Check if the controller operates properly</li> <li>- Check if the circulating pump works properly</li> <li>- Check the filter contamination upstream of the circulating pump and the flow sensor</li> <li>- Make sure that the check valve has been mounted correctly and works properly</li> </ul>
Too long waiting time for hot water at the tap	Depending on the system layout and the degree of circulation and DHW insulation, go to the controller menu and increase the circulation temperature or the circulation pump operation time

# TECH TECH CONTROLLERS

## EU Declaration of conformity

Hereby, we declare under our sole responsibility that **EU-11** manufactured by TECH STEROWNIKI II Sp. z o.o., headquartered in Wieprz Biała Droga 31, 34-122 Wieprz, is compliant with Directive **2014/35/EU** of the European Parliament and of the Council of 26 February 2014 on the harmonisation of the laws of Member States relating to **the making available on the market of electrical equipment designed for use within certain voltage limits** (EU OJ L 96, of 29.03.2014, p. 357), **Directive 2014/30/EU** of the European Parliament and of the Council of 26 February 2014 on the harmonisation of the laws of Member States relating to **electromagnetic compatibility** (EU OJ L 96 of 29.03.2014, p.79), **Directive 2009/125/EC** establishing a framework for the setting of ecodesign requirements for energy-related products as well as the regulation by the MINISTRY OF ENTREPRENEURSHIP AND TECHNOLOGY of 24 June 2019 amending the regulation concerning the essential requirements as regards the restriction of the use of certain hazardous substances in electrical and electronic equipment, implementing provisions of Directive (EU) 2017/2102 of the European Parliament and of the Council of 15 November 2017 amending Directive 2011/65/EU on the restriction of the use of certain hazardous substances in electrical and electronic equipment (OJ L 305, 21.11.2017, p. 8).

For compliance assessment, harmonized standards were used:

**PN-EN IEC 60730-2-9:2019-06, PN-EN 60730-1:2016-10, EN IEC 63000:2018 RoHS.**

Wieprz, 15.03.2021

  
Paweł Jura

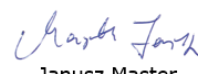
  
Janusz Master

---

Prezesa firmy

**TECH  
TECH  
CONTROLLERS**

**Central headquarters:**

ul. Biała Droga 31, 34-122 Wieprz

**Service:**

ul. Skotnica 120, 32-652 Bulowice

phone: **+48 33 875 93 80**

e-mail: **serwis@techsterowniki.pl**

[www.tech-controllers.com](http://www.tech-controllers.com)