



phone: +48 33 875 93 80
e-mail: serwis@techsterowniki.pl

Service:
ul. Skotnica 120, 32-652 Bulowice

Central headquarters:
ul. Biała Droga 31, 34-122 Wieprz

EN

EU-G-X
USER'S MANUAL

TECH
CONTROLLERS

TECH
CONTROLLERS

WARRANTY CARD

TECH STEROWNIKI II Sp. z o.o. company ensures to the Buyer proper operation of the device for the period of 24 months from the date of sale. The Guarantor undertakes to repair the device free of charge if the defects occurred through the manufacturer's fault. The device should be delivered to its manufacturer. Principles of conduct in the case of a complaint are determined by the Act on specific terms and conditions of consumer sale and amendments of the Civil Code (Journal of Laws of 5 September 2002).

CAUTION! THE TEMPERATURE SENSOR CANNOT BE IMMERSUED IN ANY LIQUID (OIL ETC). THIS MAY RESULT IN DAMAGING THE CONTROLLER AND LOSS OF WARRANTY! THE ACCEPTABLE RELATIVE HUMIDITY OF THE CONTROLLER'S ENVIRONMENT IS 5-85% REL.H. WITHOUT THE STEAM CONDENSATION EFFECT. THE DEVICE IS NOT INTENDED TO BE OPERATED BY CHILDREN.

Activities related to setting and regulation of the controller parameters described in the Instruction Manual and parts wearing out during normal operation, such as fuses, are not covered by warranty repairs. The warranty does not cover damages arising as a result of improper operation or through the user's fault, mechanical damage or damage created as a result of fire, flood, atmospheric discharges, overvoltage or short-circuit. The interference of an unauthorized service, wilful repairs, modifications and construction changes cause the loss of Warranty. TECH controllers have protective seals. Removing a seal results in the loss of Warranty.

The costs of unjustifiable service call to a defect will be borne exclusively by the buyer. The unjustifiable service call is defined as a call to remove damages not resulting from the Guarantor's fault as well as a call considered unjustifiable by the service after diagnosing the device (e.g. damage of the equipment through the fault of the client or not subject to Warranty), or if the device defect occurred for reasons lying beyond the device.

In order to execute the rights arising from this Warranty, the user is obliged, at his own cost and risk, deliver the device to the Guarantor along with a correctly filled-in warranty card (containing in particular the sale date, the seller's signature and a description of the defect) and sales proof (receipt, VAT invoice, etc.). The Warranty Card is the only basis for repair free of charge. The complaint repair time is 14 days.

When the Warranty Card is lost or damaged, the manufacturer does not issue a duplicate.

.....
seller's stamp

.....
date of sale

SAFETY

Before using the device for the first time the user should read the following regulations carefully. Not obeying the rules included in this manual may lead to personal injuries or controller damage. The user's manual should be stored in a safe place for further reference. In order to avoid accidents and errors it should be ensured that every person using the device has familiarized themselves with the principle of operation as well as security functions of the controller. If the device is to be sold or put in a different place, make sure that the user's manual is there with the device so that any potential user has access to essential information about the device.

The manufacturer does not accept responsibility for any injuries or damage resulting from negligence; therefore, users are obliged to take the necessary safety measures listed in this manual to protect their lives and property.

WARNING

- Installation should be carried out by a person holding appropriate electrical qualifications.
- The device is not intended for use by children.
- The actuator may not be used contrary to its intended purpose.

We are committed to protecting the environment. Manufacturing electronic devices imposes an obligation of providing for environmentally safe disposal of used electronic components and devices. Hence, we have been entered into a register kept by the Inspection For Environmental Protection. The crossed-out bin symbol on a product means that the product may not be disposed of to household waste containers. Recycling of wastes helps to protect the environment. The user is obliged to transfer their used equipment to a collection point where all electric and electronic components.



EU DECLARATION OF CONFORMITY

Hereby, we declare under our sole responsibility that **EU-G-X** manufactured by TECH STEROWNIKI II Sp. z o.o., head-quartered in Wieprz Biała Droga 31, 34-122 Wieprz, is compliant with Directive 2014/53/EU of the European parliament and of the Council of 16 April 2014 on the harmonisation of the laws of the Member States relating to the making available on the market of radio equipment, Directive 2009/125/EC establishing a framework for the setting of ecodesign requirements for energy-related products as well as the regulation by the MINISTRY OF ENTREPRENEURSHIP AND TECHNOLOGY of 24 June 2019 amending the regulation concerning the essential requirements as regards the restriction of the use of certain hazardous substances in electrical and electronic equipment, implementing provisions of Directive (EU) 2017/2102 of the European Parliament and of the Council of 15 November 2017 amending Directive 2011/65/EU on the restriction of the use of certain hazardous substances in electrical and electronic equipment (OJ L 305, 21.11.2017, p. 8). For compliance assessment, harmonized standards were used: PN-EN IEC 60730-2-9 :2019-06 art. 3.1a Safety of use PN-EN 62479:2011 art. 3.1 a Safety of use ETSI EN 301 489-1 V2.2.3 (2019-11) art.3.1b Electromagnetic compatibility ETSI EN 301 489-3 V2.1.1:2019-03 art.3.1 b Electromagnetic compatibility ETSI EN 300 220-2 V3.2.1 (2018-06) art.3.2 Effective and coherent use of radio spectrum ETSI EN 300 220-1 V3.1.1 (2017-02) art.3.2 Effective and coherent use of radio spectrum EN IEC 63000:2018 RoHS.

Paweł Jura *Janusz Master*
Prezesi firmy

Wieprz, 11.05.2023

TECHNICAL DATA

Power supply	2xAA 1.5V batteries
Operating frequency	868MHz
Locking ring	M30x1,5

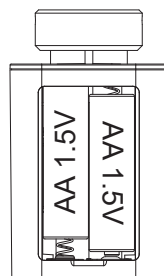

The pictures and diagrams are for illustration purposes only. The manufacturer reserves the right to introduce some changes.

DESCRIPTION

The EU-G-X device is a modern wireless thermostatic actuator designed for installation on radiator valves. It allows for convenient and effective temperature control in individual heating zones within the building. The actuator control system allows for optimal thermal comfort and promotes significant energy savings. This type of actuator can operate with both heating and cooling systems. The device is compatible with, among others, mounting strips and other controllers with wireless communication.

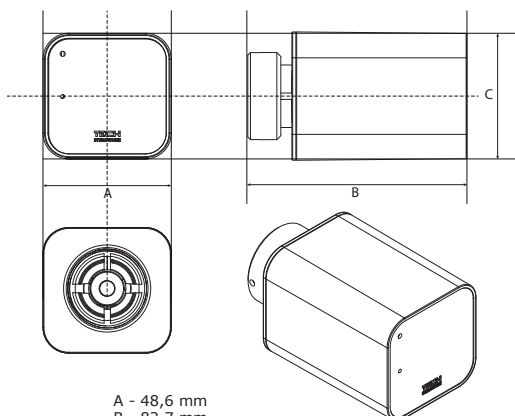

A - 48,6 mm
B - 82,7 mm
C - 47,6 mm

OPERATING PRINCIPLE

The actuator sends RC data to the controller every few minutes. On the basis of this data, the controller adjusts the opening of the actuator. The actuator will not change the opening until it receives further data from the controller.

It is possible to manually force communication. To do this, hold the communication button for 2 flashes of the LED. The next 2 flashes indicate successful communication, while 1 denotes a communication error.

After a successful communication process, the actuator sends the data to the controller, in which it informs that this action has been forced by the user. As a result of manually forcing the communication, a screen will be displayed on the controller with information in which zone the actuator is registered, as well as additional diagnostic information.

NOTE
After each battery replacement, reset the actuator by holding the communication button for 3 seconds (reset does not un-register the actuator from the master controller).

CALIBRATION

The actuator calibration takes place before the start of operation of the device, as well as cyclically during its operation.

Initial calibration process:

- To perform the initial calibration process, remove the batteries, press the communication button several times and reinsert the batteries.
- Bolt retraction** - after inserting the battery into the actuator, the screw is retracted backwards as much as possible, and the actuator adopts the mounting position.
- Mounting position** - the actuator remains in this position for approx. 30 minutes so that the user has the opportunity to register and install the actuator on the heater. Holding the button for 3 flashes of the LED will cancel the mounting position and continue the calibration.
- Maximum bolt extension** - the actuator extends the bolt until resistance is encountered on the valve. Resistance is detected as an increase in current above the preset threshold. After the maximum extension, the actuator records the valve stroke and reduces it by the set margins so that during operation it never positions the bolt too close to the minimum or maximum extension. Based on the saved stroke, it will convert the percentage of valve opening sent from the controller to the appropriate position.

The LED flashes 2 times - the calibration process was carried out correctly.

During operation, the actuator gradually calibrates, which is why this device is equipped with the **cyclic calibration** function, which is repeated every 200 shifts.

RECALIBRATION

It is possible to manually initiate recalibration. To do this, hold the communication button for 3 flashes of the LED. During this calibration, the actuator will not stop in the mounting position - the actuator therefore must be mounted on the radiator valve.

INSTALLATION

The actuator can be mounted with any valve. If installed with a Danfoss valve, use the appropriate adapter according to the diagram below.

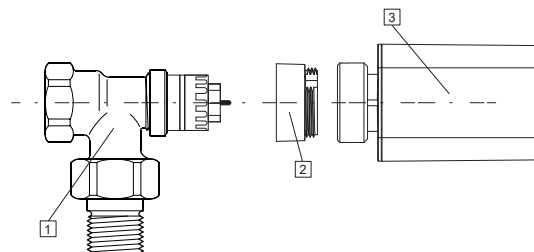

- Danfoss RA-N or RTD-N valve
- Danfoss RA-N or RTD-N adapter
- EU-G-X Actuator

REGISTRATION

To register the actuator in a specific zone, select the option to register in the main controller (please refer to its instruction manual), and then briefly press the communication button.

After releasing the button, observe the indicator LED:
- **the LED flashes 2 times** - the registration process was carried out correctly.

- **the LED is lit continuously for 2 seconds** - registration error - the operation must be repeated.

NOTE
Registration is possible while in the mounting position before installing the valve or after calibrating the actuator on the valve.

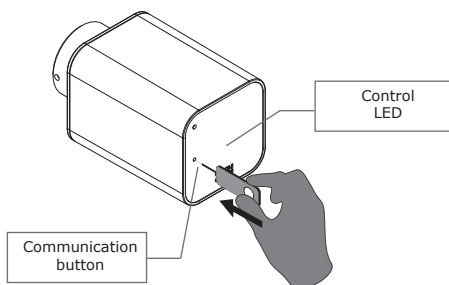

Use the tool included in the kit to register.

ALARMS

Errors in the operation of the EU-G-X actuator will be displayed on the main controller..

Error	Description	Possible causes
#1	Calibration error 1 Bolt retraction to mounting position took too long.	<ul style="list-style-type: none"> Locked/damaged actuator piston. Check the assembly and recalibrate the actuator.
#2	Calibration error 2 Bolt maximally extended as it did not meet any resistance during extension.	<ul style="list-style-type: none"> actuator was not screwed properly onto the valve the actuator was not fully tightened onto the valve actuator movement was excessive, or non-standard valve encountered motor load measurement failure occurred Check the assembly and recalibrate the actuator.
#3	Calibration error 3 Bolt extension too short. The bolt met resistance too early during the calibration process.	<ul style="list-style-type: none"> valve movement was too small, or a non-standard valve encountered motor load measurement failure motor load measurement inaccurate due to low battery charge Check the assembly and recalibrate the actuator.
#4	Actuator feedback communication error. For the last x minutes, the actuator did not receive a data package via wireless communication. After this error is triggered, the actuator will set itself to 0% opening. The error will reset after a data package is received.	<ul style="list-style-type: none"> master controller disabled poor signal or no signal originating from the master controller defective RC module in the actuator
#5	Battery low The actuator will detect battery replacement after voltage rises and launch calibration	<ul style="list-style-type: none"> battery depleted
#6	-	-
#7	Actuator blocked	<ul style="list-style-type: none"> while changing the opening of the valve, excessive load was encountered Recalibrate the actuator.