

TECH CONTROLLERS

USER MANUAL

EU-27i

EN



TECH TECH CONTROLLERS

EU DECLARATION OF CONFORMITY

Hereby, we declare under our sole responsibility that **EU-27i** manufactured by TECH, head-quartered in Wieprz Biała Droga 31, 34-122 Wieprz, is compliant with Directive **2014/35/EU** of the European Parliament and of the Council of 26 February 2014 on the harmonisation of the laws of Member States relating to **the making available on the market of electrical equipment designed for use within certain voltage limits** (EU OJ L 96, of 29.03.2014, p. 357), **Directive 2014/30/EU** of the European Parliament and of the Council of 26 February 2014 on the harmonisation of the laws of Member States relating to **electromagnetic compatibility** (EU OJ L 96 of 29.03.2014, p.79), Directive **2009/125/EC** establishing a framework for the setting of ecodesign requirements for energy-related products as well as the regulation by the MINISTRY OF ENTREPRENEURSHIP AND TECHNOLOGY of 24 June 2019 amending the regulation concerning the essential requirements as regards the restriction of the use of certain hazardous substances in electrical and electronic equipment, implementing provisions of Directive (EU) 2017/2102 of the European Parliament and of the Council of 15 November 2017 amending Directive 2011/65/EU on the restriction of the use of certain hazardous substances in electrical and electronic equipment (OJ L 305, 21.11.2017, p. 8).

For compliance assessment, harmonized standards were used:

PN-EN IEC 60730-2-9:2019-06, PN-EN 60730-1:2016-10.

PAWEŁ JURA

JANUSZ MASTER

WŁAŚCICIELE TECH SPÓŁKA Z OGRANICZONĄ ODPOWIEDZIALNOŚCIĄ SP. K.

Wieprz, **22.07.2021**

I. Safety

Before using the device for the first time the user should read the following regulations carefully. Not obeying the rules included in this manual may lead to personal injuries or controller damage. The user's manual should be stored in a safe place for further reference. In order to avoid accidents and errors it should be ensured that every person using the device has familiarized themselves with the principle of operation as well as security functions of the controller. If the device is to be sold or put in a different place, make sure that the user's manual is there with the device so that any potential user has access to essential information about the device.

The manufacturer does not accept responsibility for any injuries or damage resulting from negligence; therefore, users are obliged to take the necessary safety measures listed in this manual to protect their lives and property.

WARNING

- **High voltage!** Make sure the regulator is disconnected from the mains before performing any activities involving the power supply (plugging cables, installing the device etc.)
- The device should be installed by a qualified electrician.
- Before starting the controller, the user should measure earthing resistance of the electric motors as well as the insulation resistance of the cables.
- The regulator should not be operated by children.

WARNING

- The device may be damaged if struck by a lightning. Make sure the plug is disconnected from the power supply during storm.
- Any use other than specified by the manufacturer is forbidden.
- Before and during the heating season, the controller should be checked for condition of its cables. The user should also check if the controller is properly mounted and clean it if dusty or dirty.



will be recycled.

We are committed to protecting the environment. Manufacturing electronic devices imposes an obligation of providing for environmentally safe disposal of used electronic components and devices. Hence, we have been entered into a register kept by the Inspection For Environmental Protection. The crossed-out bin symbol on a product means that the product may not be disposed of to household waste containers. Recycling of wastes helps to protect the environment. The user is obliged to transfer their used equipment to a collection point where all electric and electronic components

II. Control panel description



III. Working rule

EU-27 regulator is intended to control the operation of CH circulation pump and the operation of additional pump (HCW or floor pump). The task of the regulator is to switch the CH pump on, if the temperature exceeds the threshold activation value and to switch the pump off when the boiler cools down (as a result of extinguishing). For the second pump, apart from activation temperature, the user adjusts the set temperature to which the pump will operate.

The regulator is equipped with a system preventing from a stoppage of CH and HCW pumps, the so-called. *anti-stop*. If the pump works for a longer period (e.g.. beyond the season), then the pump is turned on every 7 days for 1 minute. Additionally, time is saved every hour in a non - volatile EEPROM memory, thanks to which, after possible stoppage in supply, time measurement is continued.

The controller has been also equipped with the function of protection against water freezing, the so-called anti--freezing. After the sensor temperature of the CH HCW pump decreases below 7°C, the pump is switched on. The pump will work until the moment when the sensor temperature reaches the value of 9°C.

A user makes every change of parameters by means of **pulse generator knob**. Turning the knob allows to mark the requested function or change its value, while pressing the knob causes entering a given function or a confirmation of change in its value. To exit any function, use exit button.

IV. Controller functions

IV.a) Manual operation

Using this function, a user may start each active executive device of each regulator manually, independently of the others, and control alarm work.

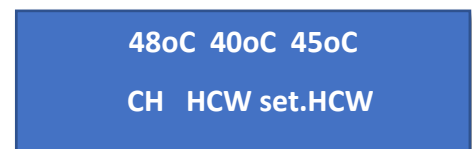

Pressing **PULSE GENERATOR** switches CH water pump on/off:

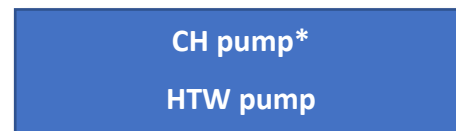
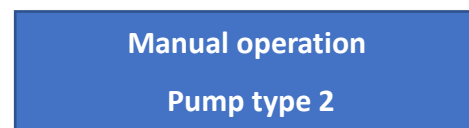

Pressing **PULSE GENERATOR** switches HTW water pump on/off:

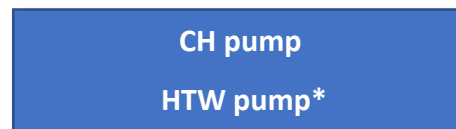

Pressing **PULSE GENERATOR** switches the alarm on/off :

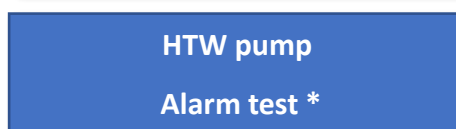

IV.b) Pump type 2

This setting allows to choose (activate) the proper type of the second pump between **HCW** and **floor pump**. If an additional pump is not connected, **No pump** option should be chosen.

Depending on the settings, additional functions will be available for the selected pumps and the appropriate screen view will be visible:

- **No pump (CH view)**

It is possible to change the activation threshold temperature directly from the main screen, using plus and minus buttons.

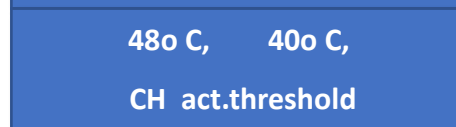
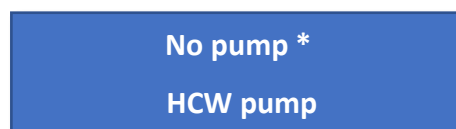

- **HCW pump (CH and HCW view)**

It is possible to change the preset HCW temperature directly from the main screen, using plus and minus buttons.

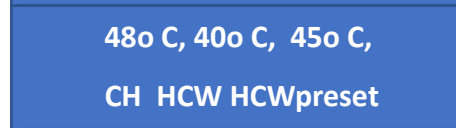
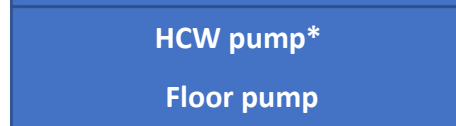

- **Floor pump (CH and floor view)**

It is possible to change the preset floor temperature directly from the main screen, using plus and minus buttons.

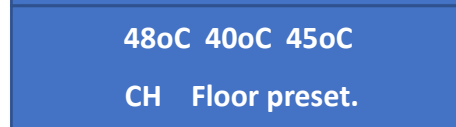
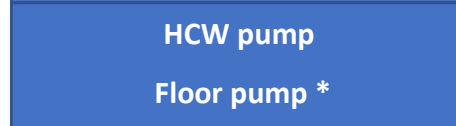

IV.c) Working mode

If pump 2 is not selected, the regulator will run according to CH pump settings (see chapter 3).

In the case of choosing the second pump as HCW, the following working modes will appear:

EU-27i User's manual

- **CH only**

In this mode, only CH pump will work, HCW pump will not be activated.

- **Simultaneous pumps**

In this mode, both pumps will be active at the same time, each according to their own settings activation.

- **HCW priority**

After selecting this mode, HCW pump will be activated first, and after reaching the preset temperature, HCW pump will be deactivated then, CH circulation pump will be activated. Re-switching to HCW pump will take place, when the reboiler temperature falls below the *preset* value by *HCW hysteresis* value.

- **Lukewarm mode**

After activating this function, CH pump is deactivated and HCW pump works according to the preset activation parameters.

In the case of selecting the second pump as floor pump, the following operating modes will appear:

- **CH only**

In this mode, only CH pump will work, floor pump will not be activated.

- **Simultaneous pumps**

In this mode, both pumps will be active at the same time, each according to their own settings activation.

- **Only floor**

After activating this function, CH pump is deactivated and floor pump works according to the preset activation parameters.

ATTENTION

In the event when there are two circulation pumps active, pump 2 (HCW or floor) is turned off, if their temperatures become equal. Re-activation will take place when the CH circulation temperature is greater by at least 2°C.

IV.d) CH pump (settings)

With this function, activation parameters of CH pump should be configured:

- **CH pump temperature**

This is a threshold activation temperature value, after reaching it, a pump starts working. The pump will be deactivated when the CH temperature falls below the activation temperature by *CH hysteresis* value.

- **CH hysteresis**

CH pump will be deactivated after the decrease in circulation temperature below the activation temperature by *CH hysteresis*.

IV.e) HCW pump (settings)

This setting shall be active, after choosing HCW pump (*MENU > pump type 2*). Using this function, activation parameters of HCW pump should be configured:

- **HCW activation temperature**

This is a threshold activation temperature value, after reaching it, a pump starts working. The pump will be deactivated when HCW temperature falls below the activation temperature by *HCW hysteresis* or reaches the preset temperature.

- **Preset HCW**

It is a temperature value of a reboiler, after reaching it, HCW is turned off. The pump will be activated

again, when the temperature falls below the preset one by *HCW hysteresis* value.

- **HCW hysteresis**

The HCW pump will be deactivated after the decrease in the temperature in circulation below the activation temperature by *HCW hysteresis*. In the event when the preset temperature is reached and the pump is deactivated, pump re-activation will take place, when the temperature falls below the preset one, by *HCW hysteresis*.

IV.f) Floor pump (settings)

this setting shall be active, after choosing the floor pump (*MENU> pump type 2*). Using this function, parameters switching on the floor pump should be configured:

- **Floor pump activation temperature**

This is a threshold activation temperature value, after reaching it, a pump starts working. The pump will be deactivated when floor temperature falls below the activation temperature by *floor hysteresis value* or reaches the preset temperature

- **Preset floor pump temperature**

It is a floor pump temperature value, after reaching it, the floor pump is deactivated. The pump will be activated again, when the temperature falls below the preset one by *floor hysteresis value*.

- **Floor pump hysteresis (*floor hysteresis*)**

Floor pump will be deactivated after the decrease in temperature in the circulation below the activation temperature by *floor hysteresis* value. In the event when the preset temperature is reached and the pump will be deactivated, pump re-activation will take place, when the temperature falls below the preset one by *floor hysteresis* value.

IV.g) Factory settings

By activating the option **factory settings**, all user's own device settings are replaced the settings saved by the manufacturer (it does not apply to servicing menu settings). From that moment, the own controller parameters may be set once again.

V. Servicing menu

In order to enter the servicing mode settings, network switch should be switched to the item O, then output button should be pressed and, without the interval, network switch should be switched to the item I. After a few seconds, the regulator enters the servicing mode. In order to return to user menu (exit servicing menu), the controller should be deactivated and activated again.

1. Alarm temperature

This function applies to securing temperature circulation. It is a critical temperature value, at which the alert sound occurs along with the respective message on the display.

2. Alarm hysteresis

After the occurrence of an alert temperature, the possibility of switching it off takes place, after the decrease of temperature below alarm value by *alarm hysteresis* value.

3. Anti-stop

This setting allows for deactivating/activating *anti-stop* function.

4. Anti--freezing

This setting allows for deactivating/activating *anti--freezing* function.

VI. Alarms

Each alarm controller is signaled with the sound, red "Alarm" diode lit on the panel, flashing screen, and the appropriate message on the screen. Leaving alarm mode proceeds by pressing any button, after the removal of the defect (or after cooling the circulation).

Below, the operated alarms are shown subsequently, according to priority:

1. No CH sensor

Text on a display:

The activation of CH pump takes place, also HCW pump is activated, if the *2nd pump* is HCW.

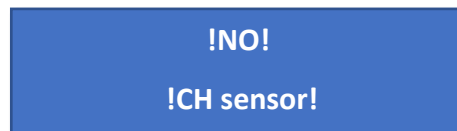

!NO!
!CH sensor!

2. Shorted CH sensor

Text on a display:

The activation of CH pump takes place, also HCW pump is activated, if the *2nd pump* is HCW.

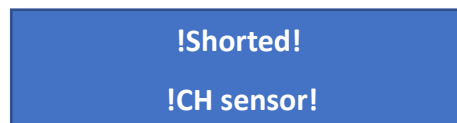

!Shorted!
!CH sensor!

3. No CHW sensor

Text on a display:

The activation of CH pump takes place. Working mode switched to "CH only". The second pump type is switched to "No pump".

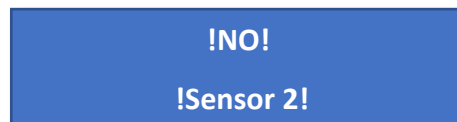

!NO!
!Sensor 2!

4. Shorted sensor 2

Text on a display:

The activation of CH pump takes place. Working mode switched to "CH only". The second pump type is switched to "No pump".

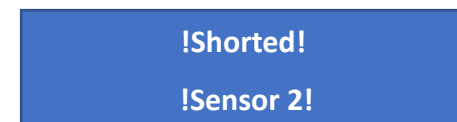

!Shorted!
!Sensor 2!

5. CH temperature above the alarm value

Text on a display:

The activation of CH pump takes place, and HCW pump is also activated, if *pump 2* is HCW pump.

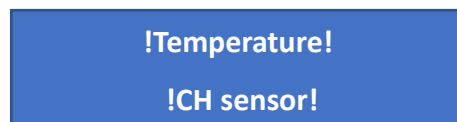

!Temperature!
!CH sensor!

6. Temperature 2 above the alarm value

Text on a display:

The activation of CH pump takes place, also HCW pump is activated, if the *2nd pump* is HCW.



!Temperature!
!Sensor 2!

7. Temperature 2 below 7°C

Text on a display:

The alarm is active only when anti-freezing option is activated. The activation of CH pump takes place, and if *pump 2* is HCW, HCW pump is also activated until reaching 9°C.

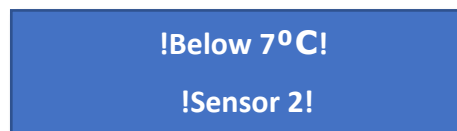

!Below 7°C!
!Sensor 2!

8. CH temperature below 7°C

Text on a display:

The alarm is active only when anti-freezing option is activated. The activation of CH pump takes place, and if *pump 2* is HCW, HCW pump is also activated until reaching 9°C.

!Below 7°C!

!CH sensor!

9. Test alarm

Text on a display:

!Alarm!

VII. Fuse

The regulator is equipped with WT 3.15 A tubular cartridge fuse, protecting the network. Using a fuse with a higher value may cause damage to the controller.

VIII. Maintenance

In **EU-27i Controller**, technical condition of wires should be checked before the heating season and throughout its duration. Fastening of the controller should be also checked, it should be cleaned from dust and other dirt. Earthing effectiveness of the engines should be also measured.

Technical Data EU-27i

Specification	Unit	
Power supply	V	230V +/-10% / 50Hz
Power consumption	W	4
Ambient Temperature	°C	5÷50
CH Pump max. output load	A	0,5
Second Pump max. output load	A	0,5
Measurement Accuracy	°C	1
Sensor Thermal Resistance	°C	-30÷99
Fuse Insert	A	3,15

for	Temperature Adjustment Range		ON threshold		OFF threshold		hysteresis		
	From	To		Max			Od	To	Fact.
CH	30 °C	70 °C	40 °C				1 °C	20 °C	2 °C
CHW	20 °C	60 °C	30 °C	55 °C	60 °C		1 °C	20 °C	2 °C
Floor	20 °C	50 °C	30 °C	45 °C	50 °C		1 °C	20 °C	2 °C
ALARM	70 °C	90 °C	85 °C				1 °C	5 °C	2 °C

IX. Assembly

Attention: The assembly should be done only by the person with proper qualifications! The device in this time must not be live (you should ensure that plug is disconnected from the grid)!

ATTENTION: wrong connection of wires can cause the damage of the regulator!

IX.a) The diagram of connecting cables to the controller.

While assembly of wiring of the controller you should pay special attention to correct connecting ground wires.

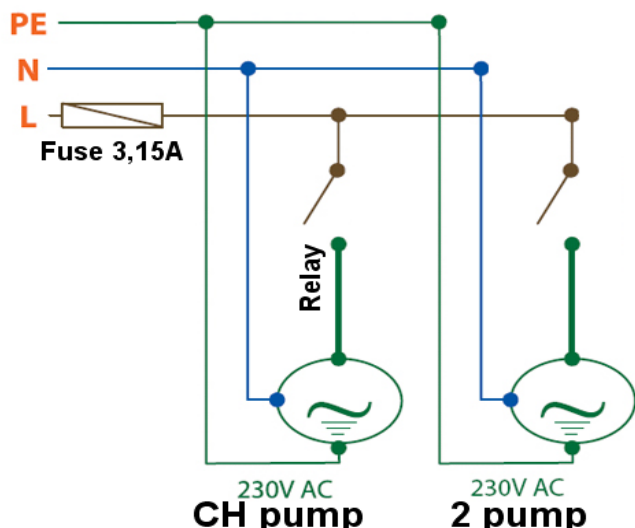

PE - earthing (yellow and green)

N - neutral (blue)

L - phase (brown)

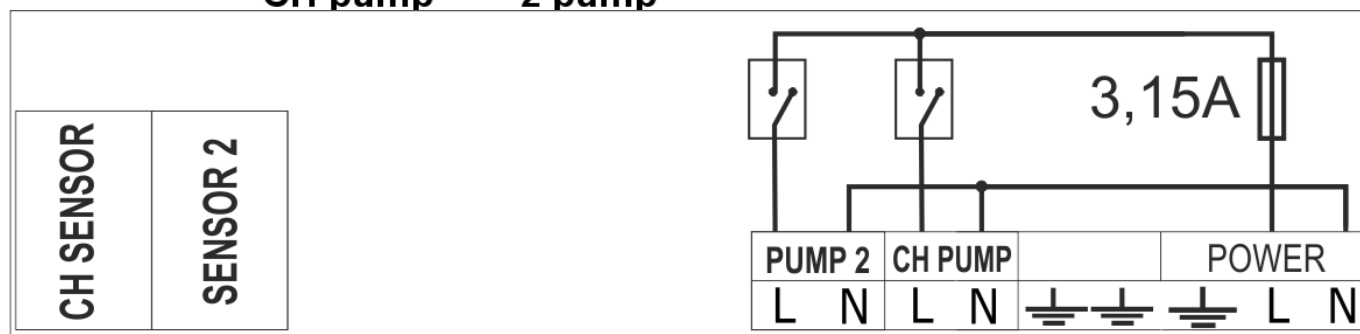

Table of contents

EU Declaration of conformity	2
I. Safety	3
II. Control panel description	4
III. Working rule	4
IV. Controller functions	4
I.	4
IV.a) Manual operation	4
IV.b) Pump type 2	5
IV.c) Working mode	5
IV.d) CH pump (settings)	6
IV.e) HCW pump (settings)	6
IV.f) Floor pump (settings)	7
IV.g) Factory settings	7
V. Servicing menu	7
VI. Alarms	8
VII. Fuse	9
VIII. Maintenance	9
IX. Assembly	10
IX.a) The diagram of connecting cables to the controller.	10

**TECH
TECH
CONTROLLERS**

Central headquarters:

ul. Biała Droga 31, 34-122 Wieprz

Service:

ul. Skotnica 120, 32-652 Bulowice

phone: **+48 33 875 93 80**

e-mail: **serwis@techsterowniki.pl**

www.tech-controllers.com